

REVISION RECORD				
REV	ECO	DESCRIPTION	DRFT	CHKD

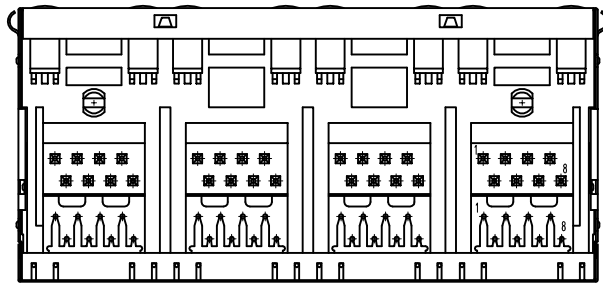
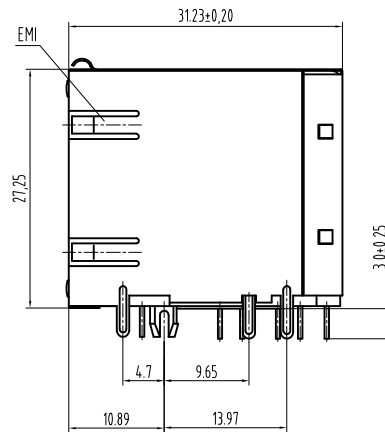
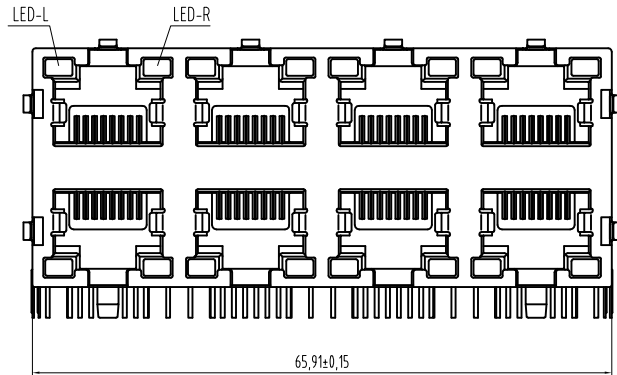

NOTES:

MATERIAL:

- | | |
|---------------------|---|
| 1. HOUSING MATERIAL | : GLASS FILLED POLYESTER UL94V-0. |
| 2. CONTACT MATERIAL | : PHOSPHOR BRONZE ϕ 0.45mm. |
| 3. PLATING | : GOLD PLATING $Fu \sim 50u$ OVER NICKEL. |
| 4. SHIELD | : 0.20mm THICKNESS COPPER ALLOY WITH NICKEL PLATED. |
| 5. LED | : OPTION |

ELECTRICAL:

- | | |
|---------------------------------------|------------------------------|
| 1. VOLTAGE RATING | : 125 VAC RMS. |
| 2. CURRENT RATING | : 1.5 AMP. |
| 3. CONTACT RESISTANCE | : 30 MILLIOHMS MAX. |
| 4. INSULATION RESISTANCE | : 500 MEGOHMS MIN @ 500V DC. |
| 5. DIELECTRIC WITHSTANDING RESISTANCE | : 1000V AC RMS 50Hz. 1MIN. |

MECHANICAL:

- | | |
|-----------------------------|-------------------|
| 1. DURRABILITY | : 750 CYCLES MIN. |
| 2. PCB RETENTION PRE-SOLDER | : 1 LB MIN. |

ENVIRONMENTAL:

- | | |
|--------------|-----------------|
| 1. STORAGE | : -40°C ~ +85°C |
| 2. OPERATION | : 0°C TO 70°C. |

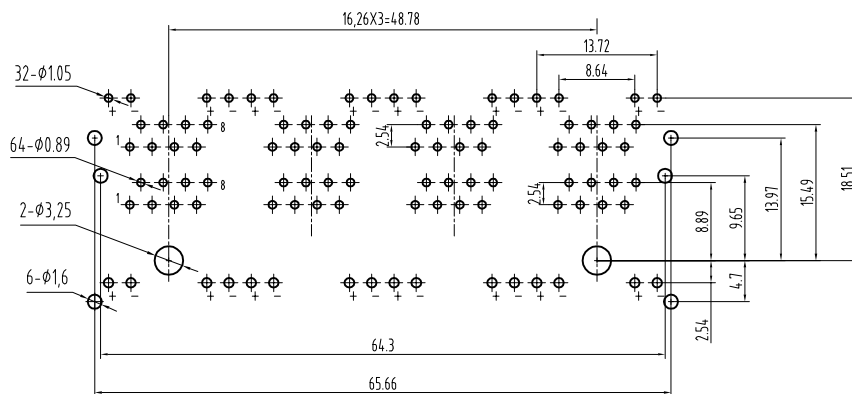

PC Board Layout
Component Side Shown

DETACHED LISTS	MM (INCH)	DFTD: SHD	DATE: 2008.03.03	<h1>Coorle Technology</h1>	
	TOLERANCES EXCEPT AS NOTED	CHKD: LANBO	DATE: 2008.03.03		
	MM	MFG:	DATE:		
	.0 ± 0.15	APPVL:	DATE:		
.06 ± 0.075	MATERIAL:			TITLE	
.00 ± 0.05	ANGLES ± 0.5	QTY:			5JB 2x4 LED JACK W/ SHIELD
THIRD ANGLE PROJECTION	FINISH:	SCALE:			DRAWING NO. TESJB002
					/PART NO.
					SIZE A3
					REV 0
					DO NOT SCALE DRAWING
					SHEET X OF Y